

## INSTALLATION, OPERATION AND MAINTENANCE GUIDE

### ISQBX Intrinsically Safe Pressure Regulator



The ISQBX series control valve is an electronic pressure regulator that precisely and proportionally controls the pressure of gaseous media based on an electronic control signal.

The ISQBX operates using two normally closed solenoid valves, a pressure sensor, and a control circuit. One valve is actuated to allow supply media into the system. The second valve is actuated to allow working media to vent through a threaded port to atmosphere. The pressure sensor provides feedback to the control circuit. The control circuit compares the pressure sensor feedback to the user supplied electronic command signal and actuates the appropriate valve until the two signals match.

The ISQBX series can be paired with a variety of air-piloted pressure volume boosters for even greater flow.

#### HAZARDOUS AREA CLASSIFICATION

The ISQBX is rated intrinsically safe and is Factory Mutual approved for Class I, II & III, Division 1, Groups C, D, E, F & G.

Entity Parameters  
 V Max=29 VDC  
 I Max=150 MA  
 Ci=0.26uF  
 Li=0



Field Wiring Drawing: ISQB-96026-2

#### Special Condition for Use:

The apparatus enclosure contains aluminum which is considered to constitute a potential risk of ignition by impact or friction. Care must be taken into account during installation and use to prevent impact or friction.

NOTES: End user must determine fitness and suitability of the ISQBX control valve for their application. The ISQBX requires the use of Intrinsically Safe barriers.

#### SPECIFICATIONS

##### ELECTRICAL

##### Supply Voltage

Supply Current	<80 mA (50 mA typical)
Command Signal	4-20 mA Differential
Command Signal Impedance	100Ω

##### MECHANICAL

Pressure Ranges	Vacuum-150 psig (29.9 in Hg (vac)-10.3 Bar)
Output Pressure†	0-100% of range
Flow Rate	0.80 SCFM @ 80 PSIG (23 L/min @ 5.52 Bar)
Min Closed End Volume	1 in <sup>3</sup>
Port Size	1/8" NPT
Filtration Recommended	40 Micron (included)
Linearity/Hysteresis	±0.4% F.S. typical
Repeatability	±0.5% F.S. typical
Accuracy	±0.5% F.S. typical

##### PHYSICAL

Operating Temperature	32-104 °F (0-40 °C) (T4)
Weight	0.90 lbs (0.408 Kg)
Housing	Blue Anodized Aluminum

#### Wetted Materials

Covers	
Port 1 (Pressure)	Port 2 (Reference)
High Temperature Polyamide	High Temperature Polyamide
Substrate	
Port 1 (Pressure)	Port 2 (Reference)
Alumina Ceramic	Alumina Ceramic
Adhesives	
Port 1 (Pressure)	Port 2 (Reference)
Epoxy, RTV	Epoxy, RTV
Electronic Components	
Port 1 (Pressure)	Port 2 (Reference)
Ceramic, Silicon	Silicon, Glass, Gold, Solder

†Pressure ranges are customer specified. Output pressures other than 100% are available.

**WARNING: BEFORE YOU BEGIN**

- Examine the product. Ensure that you received what you ordered.
- Read this guide first before you start and save it for later use.
- All compressed air/gas and power should be shut off before installing, removing or performing maintenance on this product.
- Installation and use of this product should be under the supervision and control of properly qualified personnel to avoid the risk of injury or death.
- Media vents through exhaust port. If the media is hazardous (classified), the exhaust port should be vented into a safe area.

## CONNECTIONS

### Pneumatic Connections

**CAUTION: USE ONLY THE THREAD SEALANT PROVIDED. OTHER SEALANTS, SUCH AS PTFE TAPE AND PIPE DOPE, CAN MIGRATE INTO THE FLUID SYSTEM CAUSING FAILURES.**

1. The valve can be mounted in any position without affecting performance with the exception of low pressure units, which must be mounted upright to ensure proper functionality. Mounting brackets (ordered separately) can be used to attach the unit to a panel or wall surface.
2. A 40 micron in-line filter (included) is recommended on the inlet of the ISQBX valve.
3. Connect supply pressure to the INLET PORT (I) not to exceed the rated supply pressure (see Figure 1 and Table 1).
4. Connect the OUTPUT PORT (O) to the device being controlled.
5. **If this is a vacuum or vacuum through positive pressure unit, connect vacuum supply to the EXHAUST PORT (E). Positive pressure is required on the inlet with vacuum units. FOR ANY QUESTIONS, PLEASE CALL THE FACTORY.**
6. For positive pressure only units the exhaust port can be plumbed to a point outside the work area, fitted with a muffler or left open to atmosphere as the application dictates. If the media being controlled is hazardous (classified), the threaded exhaust port should be vented into a safe area.
7. Proceed with electrical connection.

### Electrical Connections

1. All intrinsically safe installations must conform to applicable Factory Mutual recommendations, the National Electric Code, and the control drawing (Field Wiring Drawing: ISQB-96026-2), as well as any applicable local codes or fire marshal directives. All intrinsically safe installations must be performed by personnel trained in the proper application of the above.
2. Ensure all power is off before making any electrical connections.
3. Figure 1 shows the location of the ISQBX electrical connector and Figure 2 shows the connector.
4. The ISQBX must be wired in accordance with the supplied field wiring drawing.

NOTE: ALL COLOR CODES RELATE TO THE FACTORY WIRED QBT POWER CORD.

TABLE 1

Rated Pressure for ISQBX Valves

For valves ordered with MAX calibrated pressure of	MAX inlet pressure is
<10" H <sub>2</sub> O	1 PSIG (28" H <sub>2</sub> O)
10-28" H <sub>2</sub> O (1 PSIG)	6.25 PSIG (175" H <sub>2</sub> O)
1-8 PSIG	20 PSIG
8-15 PSIG	30 PSIG
15-30 PSIG	60 PSIG
30-70 PSIG	120 PSIG
70-150 PSIG	165 PSIG

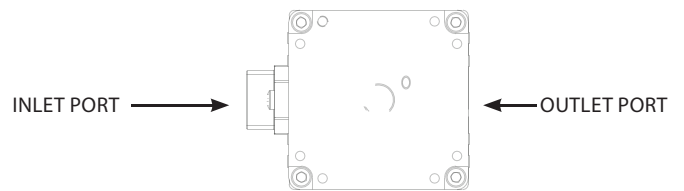
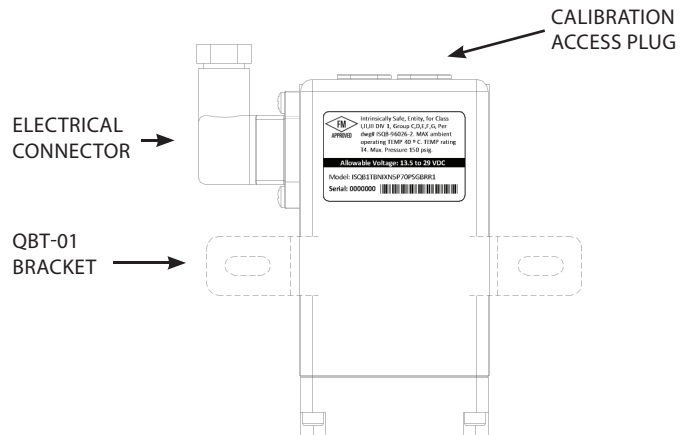

Figure 1

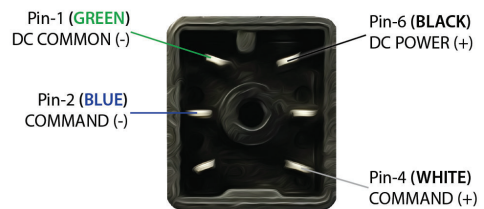

Figure 2

## RECALIBRATION PROCEDURE

All ISQBX valves come calibrated from the factory by trained personnel using precision calibration equipment. The ISQBX is a closed loop control valve using a precision electronic pressure sensor. Typical drift is less than 1% over the life of the product. If your ISQBX appears to be out of calibration by more than 1%, it is not likely to be ISQBX. Check the system for plumbing leakage, wiring and electronic signal levels. Verify the accuracy of your measuring equipment before re-calibrating. If the ISQBX valve needs re-calibration, use this procedure:

1. Wire the ISQBX according to the "Electrical Connections" section.
2. Connect a precision pressure gage or pressure transducer to the OUTLET PORT of the ISQBX.

**NOTE:** There must be a closed volume of at least 1 in<sup>3</sup> between the OUTLET PORT and the measuring device for the ISQBX to be stable.

3. Provide supply pressure to the INLET PORT of the ISQBX. (See Figure 1). Make sure supply pressure does not exceed the rating for the valve. (See Table 1)
4. Remove the calibration access plug on top of the ISQBX to access the HYSTERESIS, SPAN and ZERO adjustment potentiometers (Figure 3).

5. Only use this step if your device is totally out of calibration. If it is slightly out of calibration, skip this step and go to step 6. Using a small screwdriver, turn the ZERO and SPAN potentiometers (Figure 3) 15 turns clockwise, then 7 turns counter clockwise. This will put the IS unit roughly at mid scale.
6. Set the electrical command input to 20mADC. Adjust the SPAN potentiometer until MAXIMUM desired pressure is reached (clockwise increases pressure).
7. Set the electrical command input to 10 percent of full value (5.6mA).
8. Adjust the ZERO potentiometer until 10 percent of maximum desired pressure is reached. (clockwise increases pressure).
9. If at any time during the calibration procedure the control valve oscillates or becomes unstable for more than one second, turn the HYSTERESIS potentiometer counter-clockwise until the oscillation stops, then turn it one more complete turn (same direction).
10. The ZERO and SPAN potentiometers interact slightly. Repeat steps 6-8 until no error exists.
11. Verify unit shuts off by going to zero command. Check linearity by going to at least six pressure points throughout the full range.

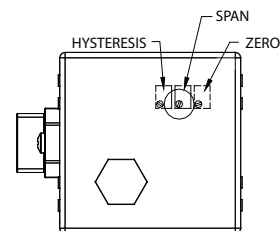
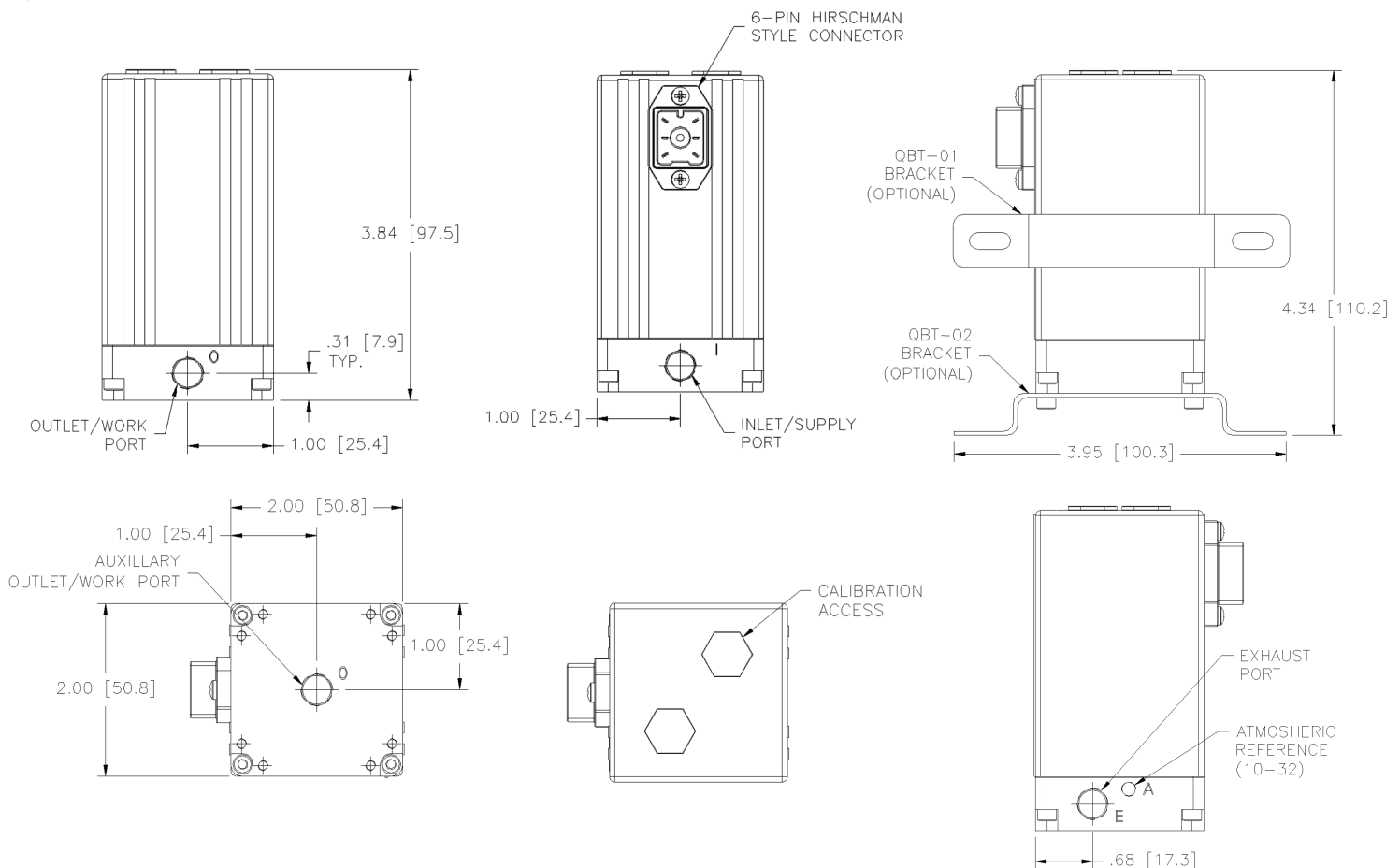

Figure 3

## ISQBX AND BRACKET DIMENSIONS



# FIELD WIRING DRAWING ISQB-96026-2 (General Barrier)

6 5 4 3 2 1

## NOTES

- A. INTRINSIC SAFETY BARRIERS MUST BE INSTALLED IN ACCORDANCE WITH THE MANUFACTURER INSTRUCTIONS
- B. THE COMBINATION OF BARRIERS UTILIZED MUST BE FM APPROVED IN THE SPECIFIC CONFIGURATION SUCH THAT:  
 $V_s \leq V_{max}$      $C_s > C_c + C_e$   
 $I_s \leq I_{Isw}$      $L_s > L_c + L_e$
- C. CONTROL ROOM EQUIPMENT CONNECTED TO BARRIERS MUST NOT USE OR GENERATE IN EXCESS OF 250 VOLTS.
- D. FOR GUIDANCE ON INSTALLATION REFER TO:  
 ANSI/ISA 12.6, "WIRING PRACTICES FOR HAZARDOUS (CLASSIFIED) INSTRUMENTATION PART 1: INTRINSIC SAFETY"  
 AND  
 NATIONAL ELECTRIC CODE (ANSI/NFPA 70)
- E. SUBSTITUTION OF COMPONENTS MAY IMPAIR INTRINSIC SAFETY
- F. FACTORY MUTUAL APPROVAL REQUIRED TO MODIFY OR CHANGE THIS DRAWING.

## RECORD OF REVISIONS

- A. ADD SHEET 3 TO INCORPORATE REVISED BARRIER PART NUMBERS FROM THE BARRIER MANUFACTURER.
- B. ADD SHEET 4 TO INCLUDE NEW ZENER BARRIER.
- C. CHANGED C1 ON ALL SHEETS FROM 0.24 uF to 0.26 uF.  
 DELETE SHEET 2, BARRIERS OBSOLETE.  
 ADD BARRIER KFDD-C5-EX1.50P AS ALTERNATE COMMAND SIGNAL BARRIER TO SHEET 4.  
 ADD SHEETS 5 & 6 TO INCLUDE NEW BARRIER MODELS.  
 ADD SHEET 7 TO INCLUDE TWO ZENER BARRIER COMBINATION.

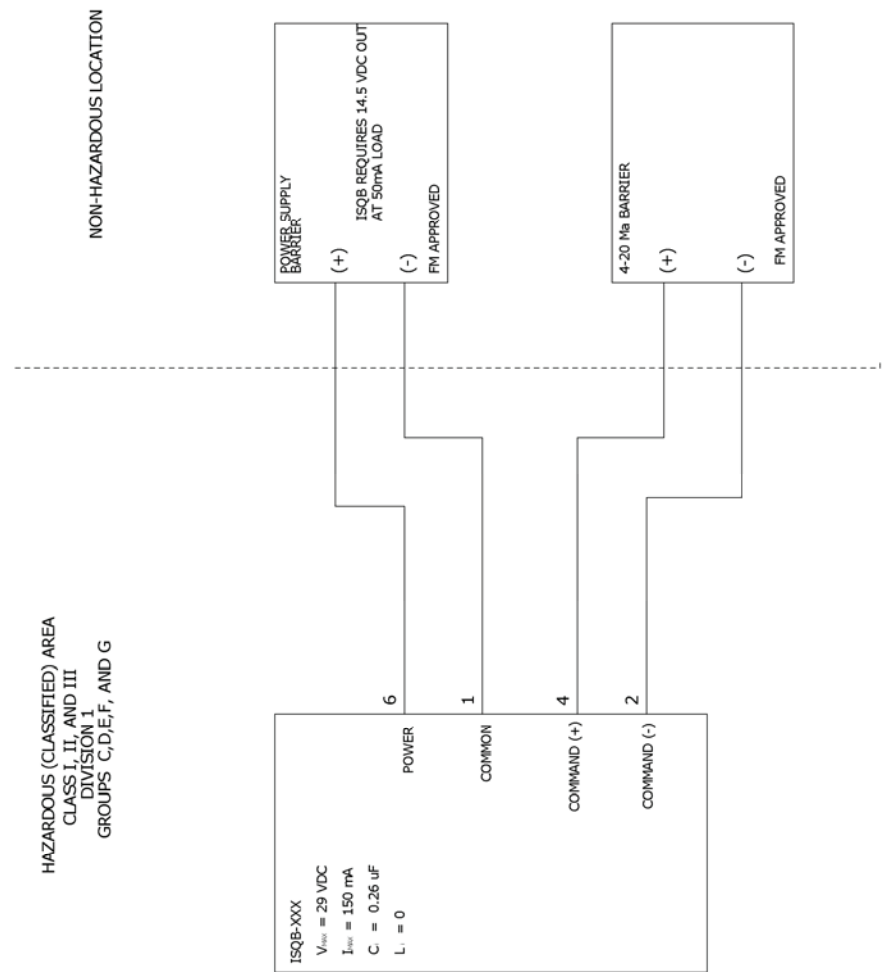

ISQB-XXX  
 $V_{max} = 29$  VDC  
 $I_{sw} = 150$  mA  
 $C_c = 0.26$  uF  
 $L_s = 0$

POWER  
 COMMON  
 COMMAND (+)  
 COMMAND (-)

POWER SUPPLY  
 BARRIER  
 (+)  
 ISQB REQUIRES 14.5 VDC OUT  
 AT 50mA LOAD  
 (-)  
 FM APPROVED

4-20 mA BARRIER  
 (+)  
 (-)  
 FM APPROVED

COMPANY: PROPORTION AIR INC.		TITLE: ISQB INTERCONNECTION DWG	
DATE:	1/26/96	DATE:	1/26/96
DRWING:	CDH	CHECKED:	CDH
DATE:	1/26/96	QUALITY CONTROL:	N/A
DATE:	N/A	RELEASED:	CDH
DATE:	11/6/14	DATE:	11/6/14
SCALE:	N/A	SCALE:	N/A
CODE:	N/A	CODE:	C
SIZE:	C	DRAWING NO.:	ISQB-96026-2
REV.:	D	REV.:	D
			SHEET: 1 OF 7

THIS DRAWING INCLUDING THE PRINCIPAL OF DESIGN INFORMATION IS THE PROPERTY OF PROPORTION AIR INC. AND IS NOT TO BE REPRODUCED, COPIED OR TRANSMITTED IN ANY MANNER WITHOUT THE WRITTEN PERMISSION OF PROPORTION AIR INC. ANY REPRODUCTION IN ANY MANNER THAT MAY CONSTITUTE A VIOLATION OF INTELLECTUAL PROPERTY RIGHTS SHALL BE CONSIDERED AS AN AGREEMENT TO THE ABOVE.

# FIELD WIRING DRAWING ISQB-96026-2 (PEPPERL-FUCHS KFD2)

6 5 4 3 2 1

## NOTES

- A. INTRINSIC SAFETY BARRIERS MUST BE INSTALLED IN ACCORDANCE WITH THE MANUFACTURER INSTRUCTIONS
- B. CONTROL ROOM EQUIPMENT CONNECTED TO BARRIERS MUST NOT USE OR GENERATE IN EXCESS OF 250 VOLTS
- C. FOR GUIDANCE ON INSTALLATION REFER TO:  
ANSI/ISA 12.6, "WIRING PRACTICES FOR HAZARDOUS (CLASSIFIED) LOCATIONS INSTRUMENTATION PART 1; INTRINSIC SAFETY" AND  
NATIONAL ELECTRIC CODE (ANSI/NFPA 70)
- D. SUBSTITUTION OF COMPONENTS MAY IMPAIR INTRINSIC SAFETY.
- E. FACTORY MUTUAL APPROVAL REQUIRED TO MODIFY OR CHANGE THIS DRAWING.

HAZARDOUS (CLASSIFIED) AREA  
CLASS I, II, AND III  
DIVISION 1  
GROUPS C,D,E,F, AND G

NON-HAZARDOUS LOCATION

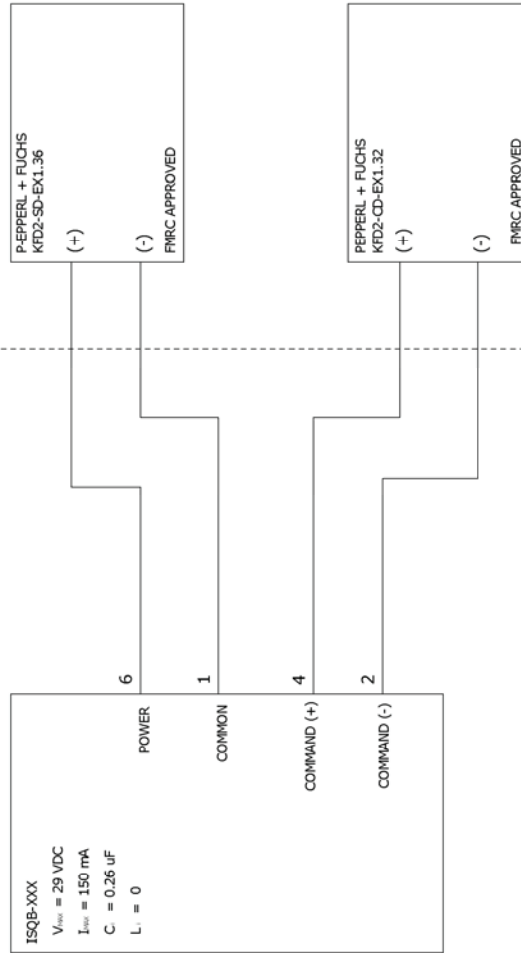

COMPANY: PROPORTION AIR INC.		TITLE: ISQB INTERCONNECTION DWG	
DATE: 1/26/96	DATE: 1/26/96	CODE: N/A	REV: D
CDH	CDH	SIZE: C	DRAWING NO: ISQB-96026-2
CHECKED: CDH	DATE: 1/26/96	SCALE: N/A	SHEET: 3 OF 7
QUALITY CONTROL: N/A	DATE: N/A		
RELEASED: CDH	DATE: 11/6/14		

THIS DRAWING INCLUDING THE PRINCIPAL OF DESIGN INFORMATION AND SPECIFICATIONS IS THE PROPERTY OF PROPORTION AIR INC. AND IS TO BE USED ONLY FOR THE PROJECT AND LOCATION FOR WHICH IT WAS PREPARED. IT IS NOT TO BE REPRODUCED, COPIED OR TRANSMITTED IN ANY MANNER THAT MAY CONSTITUTE A VIOLATION OF INTELLECTUAL PROPERTY RIGHTS OR OTHERWISE SUBJECT TO INFRINGEMENT BY ANY PARTY. PROPORTION AIR INC. SHALL BE CONSIDERED AS AN AGREEMENT TO THE ABOVE.

# FIELD WIRING DRAWING ISQB-96026-2 (PEPPERL-FUCHS Z728/KFD2)

6 5 4 3 2 1

## NOTES

- A. INTRINSIC SAFETY BARRIERS MUST BE INSTALLED IN ACCORDANCE WITH THE MANUFACTURER INSTRUCTIONS WITH THE FOLLOWING EXCEPTIONS.
 

GROUP	C, E	D, F, G
LA	3.49 mH	6.43 mH
- B. CONTROL ROOM EQUIPMENT CONNECTED TO BARRIERS MUST NOT USE OR GENERATE IN EXCESS OF 250 VOLTS
- C. FOR GUIDANCE ON INSTALLATION REFER TO: ANSII/ISA 12.6, "WIRING PRACTICES FOR HAZARDOUS (CLASSIFIED) LOCATIONS INSTRUMENTATION PART 1; INTRINSIC SAFETY" AND NATIONAL ELECTRIC CODE (ANSI/NFPA 70)
- D. SUBSTITUTION OF COMPONENTS MAY IMPAIR INTRINSIC SAFETY.
- E. FACTORY MUTUA APPROVAL REQUIRED TO MODIFY OR CHANGE THIS DRAWING.

HAZARDOUS (CLASSIFIED) AREA  
CLASS I, II, AND III  
DIVISION 1  
GROUPS C, D, E, F, AND G

NON-HAZARDOUS LOCATION

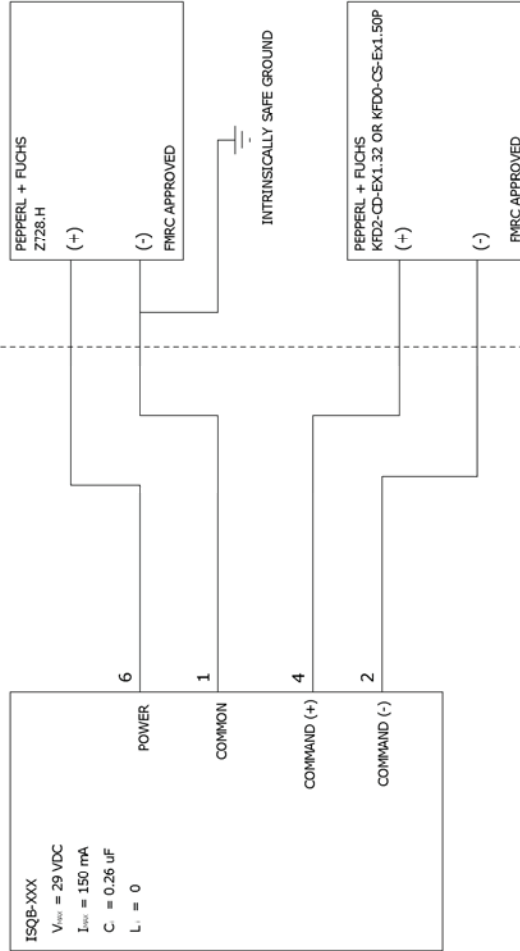

COMPANY: PROPORTION AIR INC.		TITLE: ISQB INTERCONNECTION DWG	
DATE: 1/26/96	DATE: 1/26/96	CODE: N/A	DRAWING NO: ISQB-96026-2
DRW: CDH	CHECKED: CDH	QUALITY CONTROL: N/A	RELEASED: CDH
<small>THIS DRAWING INCLUDING THE PRINCIPAL OF DESIGN INFORMATION AND DIMENSIONS IS THE PROPERTY OF PROPORTION AIR INC. AND IS TO BE USED ONLY FOR THE PROJECT AND LOCATION SPECIFICALLY IDENTIFIED HEREIN. IT IS NOT TO BE REPRODUCED, COPIED OR TRANSMITTED IN ANY MANNER THAT MAY CONSTITUTE A VIOLATION OF INTELLECTUAL PROPERTY RIGHTS OR OTHERWISE BE SUBJECT TO INFRINGEMENT BY ANY PARTY WITHOUT THE WRITTEN PERMISSION OF PROPORTION AIR INC. AS AN AGREEMENT TO THE ABOVE.</small>			REV: D
SCALE: N/A			SHEET: 4 OF 7

# FIELD WIRING DRAWING ISQB-96026-2 (PHEONIX CONTACT MACX)

6 5 4 3 2 1

## NOTES

- A. INTRINSIC SAFETY BARRIERS MUST BE INSTALLED IN ACCORDANCE WITH THE MANUFACTURER'S INSTRUCTIONS
- B. CONTROL ROOM EQUIPMENT CONNECTED TO BARRIERS MUST NOT USE OR GENERATE IN EXCESS OF 250 VOLTS
- C. FOR GUIDANCE ON INSTALLATION REFER TO:  
ANSI/ISA 12.6, "WIRING PRACTICES FOR HAZARDOUS (CLASSIFIED) LOCATIONS INSTRUMENTATION PART 1; INTRINSIC SAFETY" AND  
NATIONAL ELECTRIC CODE (ANSI/NFPA 70)
- D. SUBSTITUTION OF COMPONENTS MAY IMPAIR INTRINSIC SAFETY.
- E. FACTORY MUTUAL APPROVAL REQUIRED TO MODIFY OR CHANGE THIS DRAWING.

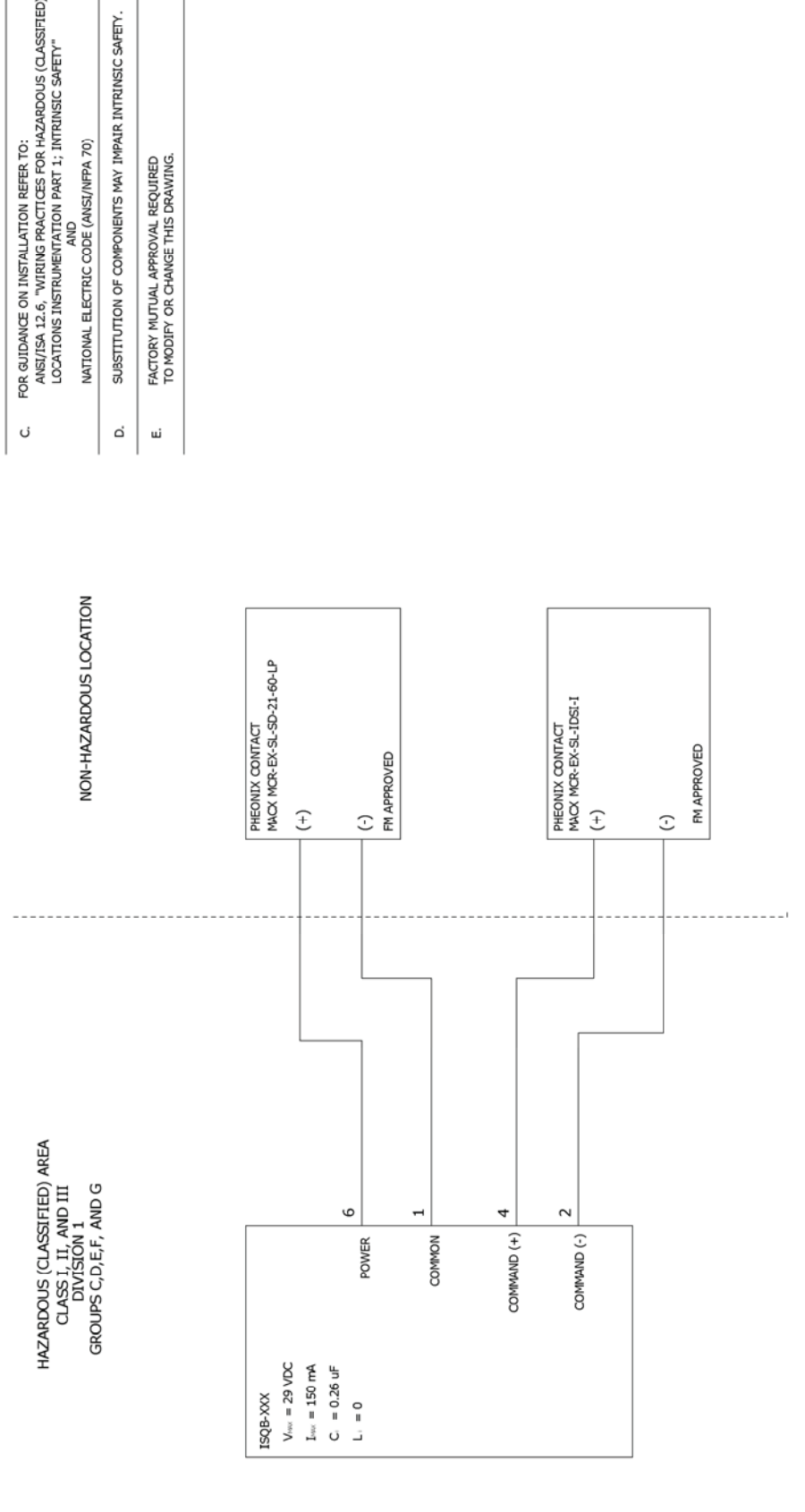

COMPANY: PROPORTION AIR INC.		DATE: 1/26/96	
TITLE: ISQB INTERCONNECTION DWG		DESIGNED BY: CDH	DATE: 1/26/96
CODE: N/A	SIZE: C	CHECKED BY: CDH	DATE: 1/26/96
DRAWING NO: ISQB-96026-2	REV: D	QUALITY CONTROL: N/A	DATE: N/A
SCALE: N/A	SHEET: 5 OF 7	RELEASED BY: CDH	DATE: 11/6/14

THIS DRAWING INCLUDING THE PRINCIPAL OF DESIGN INFORMATION IS THE PROPERTY OF PROPORTION AIR INC. AND IS NOT TO BE REPRODUCED, COPIED OR TRANSMITTED IN ANY MANNER WITHOUT THE WRITTEN PERMISSION OF PROPORTION AIR INC. ANY REPRODUCTION IN ANY MANNER THAT MAY CONSTITUTE A VIOLATION OF INTELLECTUAL PROPERTY RIGHTS SHALL BE CONSIDERED AS AN AGREEMENT TO THE ABOVE.

# FIELD WIRING DRAWING ISQB-96026-2 (PEPPERL-FUCHS KFD0)

1 2 3 4 5 6

## NOTES

- A. INTRINSIC SAFETY BARRIERS MUST BE INSTALLED IN ACCORDANCE WITH THE MANUFACTURER INSTRUCTIONS
- B. CONTROL ROOM EQUIPMENT CONNECTED TO BARRIERS MUST NOT USE OR GENERATE IN EXCESS OF 250 VOLTS
- C. FOR GUIDANCE ON INSTALLATION REFER TO: ANS/ISA 12.6, "WIRING PRACTICES FOR HAZARDOUS (CLASSIFIED) LOCATIONS INSTRUMENTATION PART 1; INTRINSIC SAFETY" AND NATIONAL ELECTRIC CODE (ANSI/NFPA 70)
- D. SUBSTITUTION OF COMPONENTS MAY IMPAIR INTRINSIC SAFETY.
- E. FACTORY MUTUAL APPROVAL REQUIRED TO MODIFY OR CHANGE THIS DRAWING.

HAZARDOUS (CLASSIFIED) AREA  
CLASS I, II, AND III  
DIVISION 1  
GROUPS C,D,E,F, AND G

NON-HAZARDOUS LOCATION

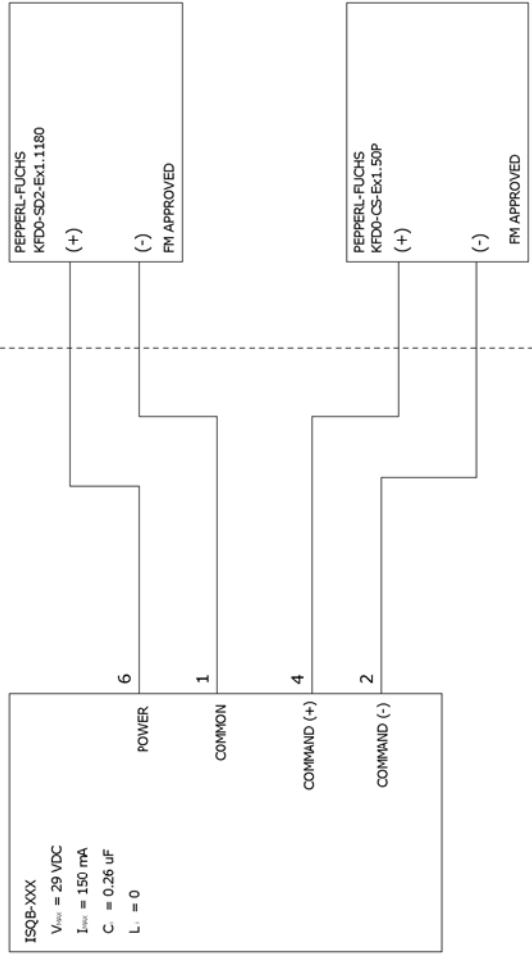

COMPANY:	PROPORTION AIR INC.			
TITLE:	ISQB INTERCONNECTION DWG			
DATE:	1/26/96	DATE:	1/26/96	REV:
DRW:	CDH	CHECKED:	CDH	DRAWING NO:
DATE:	1/26/96	QUALITY CONTROL:	N/A	SIZE:
DATE:	N/A	RELEASED:	CDH	CODE:
DATE:	11/6/14			N/A
SCALE:	N/A			SHEET: 6 OF 7

THIS DRAWING IS THE PROPERTY OF DESIGN AND IS NOT TO BE REPRODUCED OR TRANSMITTED IN ANY FORM OR BY ANY MEANS, ELECTRONIC OR MECHANICAL, INCLUDING PHOTOCOPYING, RECORDING, OR BY ANY INFORMATION STORAGE AND RETRIEVAL SYSTEM, WITHOUT THE WRITTEN PERMISSION OF PROPORTION AIR. THIS DRAWING IS TO BE USED IN ANY MANNER THAT MAY CONSTITUTE A BREACH OF THE TERMS AND CONDITIONS OF THE AGREEMENT AS AN AGREEMENT TO THE ABOVE.



# FIELD WIRING DRAWING ISQB-96026-2 (PEPPERL-FUCHS Z728)

6 5 4 3 2 1

## NOTES

- A. INTRINSIC SAFETY BARRIERS MUST BE INSTALLED IN ACCORDANCE WITH THE MANUFACTURER INSTRUCTIONS WITH THE FOLLOWING EXCEPTIONS.
 

GROUP	C, E	D, F, G
LA	3.49 mH	6.43 mH
- B. CONTROL ROOM EQUIPMENT CONNECTED TO BARRIERS MUST NOT USE OR GENERATE IN EXCESS OF 250 VOLTS
- C. FOR GUIDANCE ON INSTALLATION REFER TO: ANSI/ISA 12.6, "WIRING PRACTICES FOR HAZARDOUS (CLASSIFIED) LOCATIONS INSTRUMENTATION PART 1; INTRINSIC SAFETY" AND NATIONAL ELECTRIC CODE (ANSI/NFPA 70)
- D. SUBSTITUTION OF COMPONENTS MAY IMPAIR INTRINSIC SAFETY.
- E. FACTORY MUTUAL APPROVAL REQUIRED TO MODIFY OR CHANGE THIS DRAWING.

HAZARDOUS (CLASSIFIED) AREA  
CLASS I, II, AND III  
DIVISION 1  
GROUPS C, D, E, F, AND G

NON-HAZARDOUS LOCATION

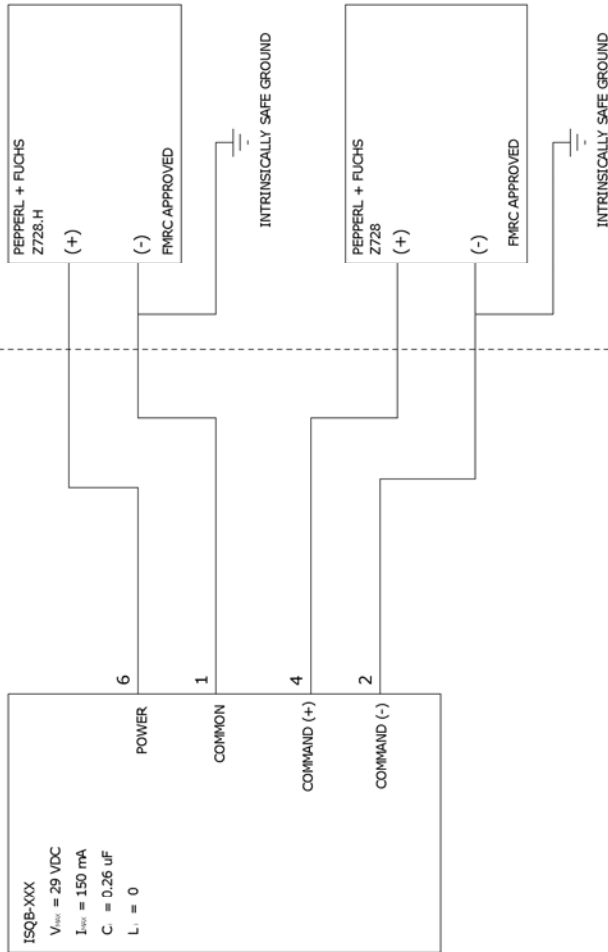

COMPANY:	PROPORTION AIR INC.		
TITLE:	ISQB INTERCONNECTION DWG		
DATE:	1/26/96	DATE:	1/26/96
CHECKED:	CDH	DATE:	1/26/96
QUALITY CONTROL:	N/A	DATE:	N/A
RELEASED:	CDH	DATE:	11/6/14
SCALE:	N/A	DRAWING NO.:	ISQB-96026-2
		SIZE:	C
		CODE:	N/A
		REV:	D
		SHEET:	7 OF 7

THIS DRAWING INCLUDING THE PRINCIPAL OF DESIGN INFORMATION AND DIMENSIONS IS THE PROPERTY OF PROPORTION AIR INC. AND IS NOT TO BE REPRODUCED, COPIED OR TRANSMITTED IN ANY MANNER THAT MAY CONSTITUTE A VIOLATION OF INTELLECTUAL PROPERTY RIGHTS. ANY REVISIONS TO THIS DRAWING SHALL BE CONTAINED AS AN AGREEMENT TO THE ABOVE.

# ISQBX CONFIGURATION

Example Part Number												
ISQBX	B	N	I	X	Z		P	10	BR	G	BR	
1	2	3	4	5	6	7	8	9	10	11	OPTIONS	

## Section Reference

1	Series
ISF1T	Nonincendive ISF
ISQBF	Nonincendive ISQBF
ISQB1T	Intrinsically Safe ISQB
ISQBX	Intrinsically Safe ISQBX
ISQB3T	Intrinsically Safe ISQB3
ISQB4T	Intrinsically Safe ISQB4

2	Manifold Material
B	Brass
A	Anodized Aluminum

3	Thread Type
N	NPT
P	BSPP (Brass Manifold Only)

4	Input Signal Range
I	4 to 20 mA DC

5	Output Signal Range
X	No Monitor

6	Zero Offset
N	0% Pressure is Below Zero
P	0% Pressure is Above Zero
Z	0% Pressure is Zero (Typical)

7	Zero Offset Pressure
Typical is 0% - If greater than 30% of full scale pressure (#9 below), please consult factory.	
*If Z for Zero Offset, Please Leave this Section (#7) Blank	

8	Full Scale Pressure Type
N	100% Pressure is Below Zero
P	100% Pressure is Above Zero
Z	100% Pressure is Zero

9	Full Scale Pressure
Must be less than or equal to 150 psig	

10	Pressure Unit (no additional fee)		
PS	PSI	Inches Hg	IH
MB	Millibars	Inches H <sub>2</sub> O	IW
BR	Bar	Millimeters H <sub>2</sub> O	MW
KP	Kilo-pascal	Kilograms/cm <sup>2</sup>	KG
MP	Mega-pascal	Torr (Requires A for Unit of Measure #11)	TR
MH	Millimeters Hg	Centimeters H <sub>2</sub> O	CW
PA	Pascal		

11	Pressure Unit of Measure	
A	Absolute Pressure	
G	Gauge Pressure	

Common Options	
BR	Install Foot Bracket
O2	Oxygen Cleaned
O3	O2 Cleaned for Non-Oxygen Use
R1	Rotate Connector 180 Degrees

Recommended Accessories	
QBT-01	Wrap-Around Mounting Bracket
QBT-02	Foot-Mount Bracket (Installed)*
* Use Option BR for Foot-Mount Bracket	



## Safety Precautions

Please read the following safety precautions before installing or operating any Proportion-Air, Inc. equipment or accessories. To confirm safety, be sure to observe 'ISO 4414: Pneumatic Fluid Power - General rules relating to systems' and other safety practices.

### Warning

Improper operation could result in serious injury to persons or loss of life!

- PRODUCT COMPATIBILITY**  
Proportion-Air, Inc. products and accessories are for use in industrial pneumatic applications with compressed air media. The compatibility of the equipment is the responsibility of the end user. Product performance and safety are the responsibility of the person who determined the compatibility of the system. Also, this person is responsible for continuously reviewing the suitability of the products specified for the system, referencing the latest catalog, installation manual, Safety Precautions and all materials related to the product.
- EMERGENCY SHUTOFF**  
Proportion-Air, Inc. products cannot be used as an emergency shutoff. A redundant safety system should be installed in the system to prevent serious injury or loss of life.
- EXPLOSIVE ATMOSPHERES**  
Products and equipment should not be used where harmful, corrosive or explosive materials or gases are present. Unless certified, Proportion-Air, Inc. products cannot be used with flammable gases or in hazardous environments.
- AIR QUALITY**  
Clean, dry air is not required for Proportion-Air, Inc. products. However, a 40 micron particulate filter is recommended to prevent solid contamination from entering the product.
- TEMPERATURE**  
Products should be used with a media and ambient environment inside of the specified temperature range of 32°F to 158°F. Consult factory for expanded temperature ranges.
- OPERATION**  
Only trained and certified personnel should operate electronic and pneumatic machinery and equipment. Electronics and pneumatics are very dangerous when handled incorrectly. All industry standard safety guidelines should be observed.
- SERVICE AND MAINTENANCE**  
Service and maintenance of machinery and equipment should only be handled by trained and experienced operators. Inspection should only be performed after safety has been confirmed. Ensure all supply pressure has been exhausted and residual energy (compressed gas, springs, gravity, etc.) has been released in the entire system prior to removing equipment for service or maintenance.

### Caution

Improper operation could result in serious injury to persons or damages to equipment!

- PNEUMATIC CONNECTION**  
All pipes, pneumatic hose and tubing should be free of all contamination, debris and chips prior to installation. Flush pipes with compressed air to remove any loose particles.
- THREAD SEALANT**  
To prevent product contamination, thread tape is not recommended. Instead, a non-migrating thread sealant is recommended for installation. Apply sealant a couple threads from the end of the pipe thread to prevent contamination.
- ELECTRICAL CONNECTION**  
To prevent electronic damage, all electrical specifications should be reviewed and all electrical connections should be verified prior to operation.

### Exemption from Liability

- Proportion-Air, Inc. is exempted from any damages resulting from any operations not contained within the catalogs and/or instruction manuals and operations outside the range of its product specifications.
- Proportion-Air, Inc. is exempted from any damage or loss whatsoever caused by malfunctions of its products when combined with other devices or software.
- Proportion-Air, Inc. and its employees shall be exempted from any damage or loss resulting from earthquakes, fire, third person actions, accidents, intentional or unintentional operator error, product misapplication or irregular operating conditions.
- Proportion-Air, Inc. and its employees shall be exempted from any damage or loss, either direct or indirect, including consequential damage or loss, claims, proceedings, demands, costs, expenses, judgments, awards, loss of profits or loss of chance and any other liability whatsoever including legal expenses and costs, which may be suffered or incurred, whether in tort (including negligence), contract, breach of statutory duty, equity or otherwise.

### Warranty

Proportion-Air, Inc. products are warranted to the original purchaser only against defects in material or workmanship for one (1) year from the date of manufacture. The extent of Proportion-Air's liability under this warranty is limited to repair or replacement of the defective unit at Proportion-Air's option. Proportion-Air shall have no liability under this warranty where improper installation or filtration occurred.

**PLEASE NOTE:** The user has the additional responsibility of supplying and/or ensuring that the connector/cable that is used with any Proportion-Air ISQBX series FM-approved product meets all local and national codes for intrinsically safe wiring.



PROPORTION-AIR, INC.  
8250 N 600 W, P.O. Box 218  
McCordsville, IN 46055  
317.335.2602  
info@proportionair.com